



SPARTAN SPZ-FL48C LED Zone 2 Floodlight Crane Luminaire

rayTEC®



- ATEX and IEC Ex approved – Zone 2
UL/CSA approved, including C1D2 and ABS
- Zone 1 variant also available
- Rotary damper ensures light is constantly targeted where required
- Easy installation, maintenance and inspection
- Ultra long life LED
- High lumen output LED
- Wide operating temperature range -10° to +55°C
- Two anchor points for safety suspension cord
- Integral photocell (optional)
- 5 year warranty
- Now 'op is' approved (EN60079-28)

The SPARTAN Crane luminaire is designed specifically for use on Marine/Offshore boom cranes where high performance, high reliability, White-Light illumination is required to ensure the safety of crane operations. Using Raytec's field-proven, long-life LED technology, SPARTAN floodlights are ATEX and IEC Ex approved for all Zone 1 applications and rated for T4 environments. The SPARTAN Crane luminaire features a stainless steel rotary damper which ensures the unit always illuminates the area directly below the crane and prevents the luminaire swinging as the crane boom moves up and down. In an application where luminaires are subject to large amounts of vibration, existing traditional floodlights used in crane applications require constant maintenance to keep the luminaire in working order. In contrast, the LEDs of the SPARTAN Crane luminaire are naturally resistant to vibration, allowing for extremely low maintenance operation.

SPARTAN is designed to provide a high quality white light illumination to ensure safe operation of the crane for both operator and personnel working in the near vicinity, leading to improved productivity and a safer working environment. SPARTAN uses **COOLEXTRUDE™** thermal management technology, ensuring a much cooler LED operating temperature and up to 60% better heat dissipation compared to traditional lighting solutions, allowing the product to operate for > 10 years while still delivering a high lumen output of up to 11,000 lumens.

Product Dimensions

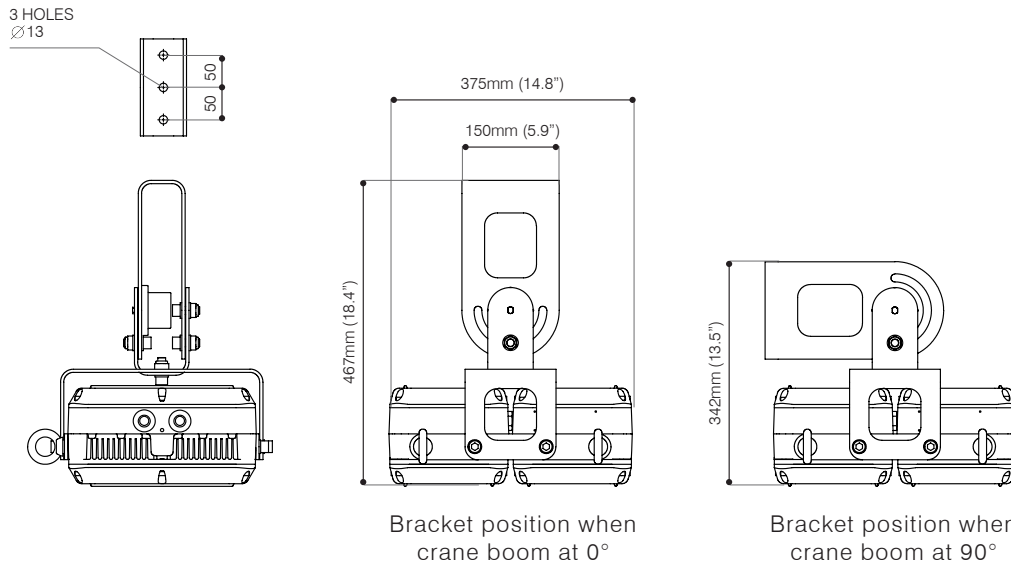

Features	Benefits
Ultra-Powerful	High lumen output - up to 11,000 lumens Latest high power LED technology
Ultra-Flexible	Operating temperature range of -10°C to + 55°C with a T4 rating for even the most challenging conditions.
Ultra-Reliable	Industry leading 5 year warranty Designed & manufactured in the UK to the highest standards including both ISO9001 & ISO14001. Advanced electronics and LED's protected by vibration resistant and water proof potting compound. Built with marine grade aluminium and marine grade 316L stainless steel bracketry for long life.
Ultra-Modular	Both the LED and PSU modules are easily accessible for maintenance and inspection
Ultra-Efficient	COOLEXTRUDE™ thermal management delivers class leading energy efficiency Significant running and maintenance savings compared to traditional lighting technologies SMART access wiring system for safe and efficient installation, set-up and ongoing inspection
Ultra-Support	Photometric files available (.ies & .ldt) Full Lighting Design Service Site specific Energy and Cost Saving Report available

5 YEAR WARRANTY

All Raytec luminaires are provided with an industry leading 5 year warranty and have an expected useful life in excess of 10 years



Technical Specifications

Certification

ATEX Rating:	ATEX and IEC Ex rated for Gas and Dust
Hazardous Area rating:	Zone 2 – Gas and Dust
Certificates:	CML 17ATEX4231 & IEC Ex CML 17.0135 UL/CSA, including C1D2
Gas:	II 3 G D Ex ec mc op is IIC T4 Gc Ta= Up to -10°C to +55°C
Dust:	Ex tb op is IIIC T82°C Dc Ta= Up to -10°C to +55°C IP66/IP67

Electrical

Input:	110-254V 50/60Hz AC only Low voltage: 18-48V AC and 18-69V DC Extra low voltage: 12V AC/DC
Power:	136W - Standard
Termination	Incoming terminal block suitable for looping 4 core 4mm ² cable
Power Factor:	>0.95
Cable Entries	2xM20 as standard (other entries available upon request), dispatched complete with three ATEX/IEC Ex approved blanking plug

Optical

Lumen Output:	Up to 11,000 lm
LED type:	Platinum Elite SMT LEDs
Number of LEDs:	48
CRI	80+
Colour Temperature:	6,000K+

Mechanical/Environmental

Burning position:	Universal
IP rating:	IP66 & IP67
Temperature range:	-10°C to +55°C
Weight:	25kg (55.1lbs)
Enclosure:	Marine grade aluminium epoxy powder coated, toughened glass, all external fasteners and brackets are marine grade stainless steel
Unit Colour:	Front - Dark Grey (RAL 7012) Back - Silver (RAL 9006)
Installation instructions:	Please contact Raytec for copy
Dimensions:	See previous page
Mounting:	Via 3 x M12 bolts (not supplied) Two anchor points provided for use with safety cord (not supplied)

Product Codes - Zone 2

Part Codes	Description (T4 variants as standard)
SPZ-FL48C-W-1010	SPARTAN Flood Crane Luminaire, 48 LED, White-Light, 10°x 10° beam

Add -C1D2 to part code for North American standards

18-69V variants available, add -LV to the above codes
12V variants available, add -ELV to the above codes

Measurement of Light Diagram (10°x10° Beam)

Mounting Height (m)	Beam Diameter (m)	Peak (lux)	Average (lux)	Minimum (lux)
10	1.75	1700	1220	847
20	3.50	421	302	204
30	5.25	185	134	91
40	7.00	104	75	51
50	8.75	67	48	32
60	10.50	47	33	23
70	12.25	34	25	17
80	14.00	26	19	13
90	15.75	21	15	10
100	17.50	17	12	8

Other beam patterns available on request

Products in the SPARTAN Crane range

Zone 1, Zone 2, UL/CSA, Industrial

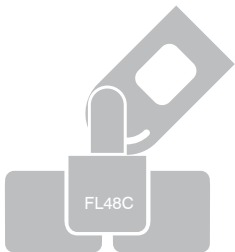

Products in the SPARTAN Family



SPARTAN Flood

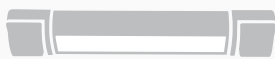

SPARTAN Linear

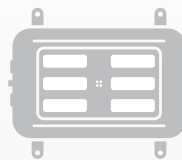

SPARTAN Bulkhead



SPARTAN Bay



SPARTAN Crane